

Self-priming "JET" pumps

-  Clean water
-  Domestic use
-  Civil use
-  Industrial use



PERFORMANCE RANGE

- Flow rate up to **160 l/min** (9.6 m³/h)
- Head up to **97 m**

APPLICATION LIMITS

- Manometric suction lift up to **9 m** (HS)
- Liquid temperature between **-10 °C** and **+40 °C**
- Ambient temperature up to **+40 °C**
- Max. working pressure **10 bar**
- Continuous service **S1**

CONSTRUCTION AND SAFETY STANDARDS

EN 60335-1
IEC 60335-1
CEI 61-150

EN 60034-1
IEC 60034-1
CEI 2-3



CERTIFICATIONS

Company with management system certified DNV
ISO 9001: QUALITY



INSTALLATION AND USE

Suitable for use with clean water and with liquids that are not chemically aggressive towards the materials from which the pump is made. The self-priming **JSW** pumps are designed to pump water even in cases where air is present. Because of their reliability and the fact that they are easy to use, they are recommended for use in domestic, civil and industrial applications such as the distribution of water in combination with pressure tanks, and for the irrigation of gardens and orchards, etc. Installation needs to be undertaken in well ventilated closed areas or anyway protected from bad weather.

PATENTS - TRADE MARKS - MODELS

- Registered Trade Mark n. 013073135 JSW[®]
- Registered EU Design n. 002218610

OPTIONS AVAILABLE ON REQUEST

- Other voltages or 60 Hz frequency
- IPX5 protection

CHARACTERISTIC CURVES AND PERFORMANCE DATA

50 Hz n= 2900 min⁻¹ HS= 0 m

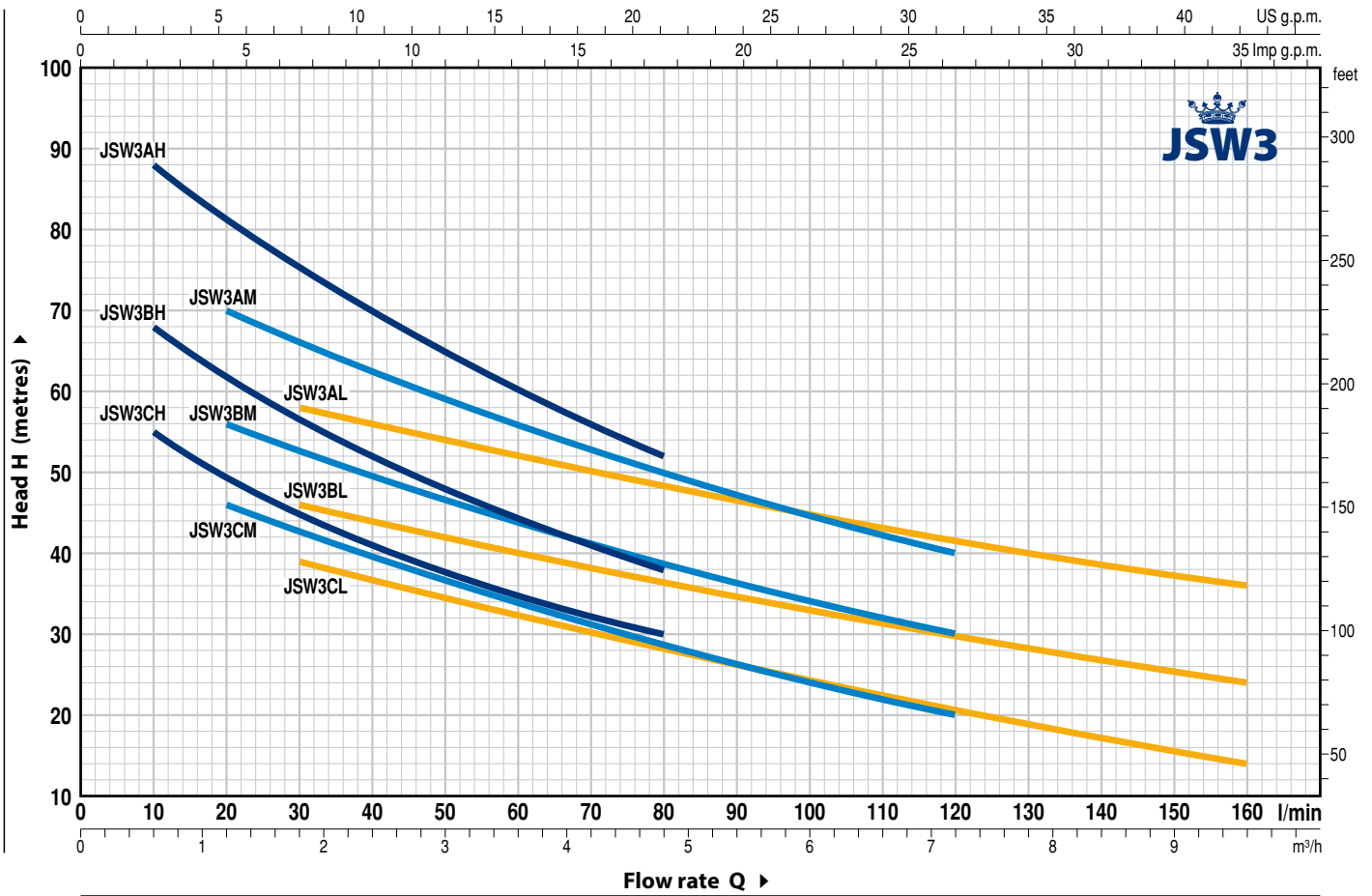

MODEL		POWER (P ₂)		▲	Q	Flow rate (m³/h)															
Single-phase	Three-phase	kW	HP			0	0.6	1.2	1.8	2.4	3.0	3.6	4.2	4.8	6.0	7.2	8.4	9.6			
JSWm 3CH	JSW 3CH	1.1	1.5	IE3	H metres	62	55	49	45	41	38	35	32	30							
JSWm 3BH	JSW 3BH	1.5	2			73	68	62	56.5	52	48	44	41	38							
JSWm 3AH	JSW 3AH	2.2	3			97	88	81	75	70	65	60.5	56	52							
JSWm 3CM	JSW 3CM	1.1	1.5			54	-	46	43	39.5	36.5	34	31	28.5	24	20					
JSWm 3BM	JSW 3BM	1.5	2			63	-	56	53	49.5	47.5	44	41	39	34	30					
JSWm 3AM	JSW 3AM	2.2	3			78	-	70	66	62	59	56	53	50	45	40					
JSWm 3CL	JSW 3CL	1.1	1.5			44	-	-	39	37	34	32	30	28	24	21	17	14			
JSWm 3BL	JSW 3BL	1.5	2			51	-	-	46	44	42	40	38	36	33	30	27	24			
JSWm 3AL	JSW 3AL	2.2	3			64	-	-	58	56	54	52	50	48	45	41.5	38.5	36			

Q = Flow rate H = Total manometric head HS = Suction height

Tolerance of characteristic curves in compliance with EN ISO 9906 Grade 3B.

▲ Three-phase motor efficiency class (IEC 60034-30-1)

STANDARD INSTALLATION

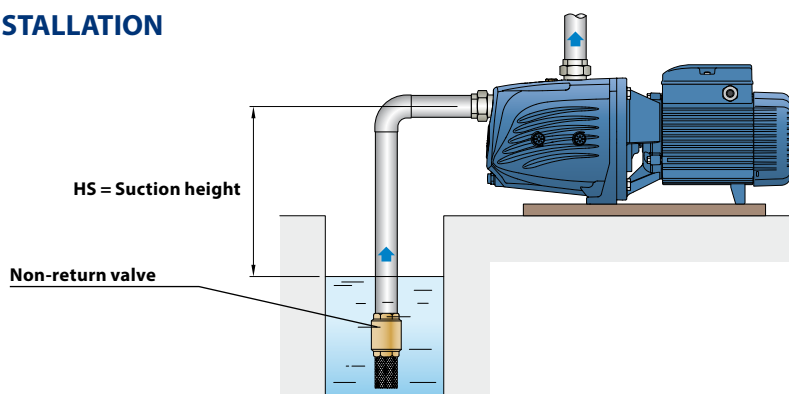

POS. COMPONENT CONSTRUCTION CHARACTERISTICS

1	PUMP BODY	Cast iron with an Epoxy Electro Coating treatment, with threaded ports in compliance with ISO 228/1				
2	BODY BACKPLATE	Cast iron				
3	NOZZLE ASSEMBLY	Noryl FE1520PW				
4	IMPELLER	Stainless steel AISI 304				
5	MOTOR SHAFT	Stainless steel AISI 431				
6	MECHANICAL SEAL	Seal	Shaft	Materials		
		Model	Diameter	Stationary ring	Rotational ring	Elastomer
		FN-18	Ø 18 mm	Graphite	Ceramic	NBR
7	BEARINGS	6204 ZZ / 6204 ZZ				
8	CAPACITOR	Pump	Capacitance			
		<i>Single-phase</i>	<i>(230 V or 240 V)</i>	<i>(110 V)</i>		
		JSWm 3C	31.5 µF - 450 VL	60 µF - 250 VL		
		JSWm 3B	45 µF - 450 VL	80 µF - 250 VL		
		JSWm 3A	50 µF - 450 VL	-		
9	ELECTRIC MOTOR	JSWm: single-phase 230 V - 50 Hz with thermal overload protector incorporated into the winding. JSW: three-phase 230/400 V - 50 Hz. ⇒ The three-phase pumps are fitted with high performance motors in class IE3 (IEC 60034-30-1) – Insulation: class F – Protection: IP X4				

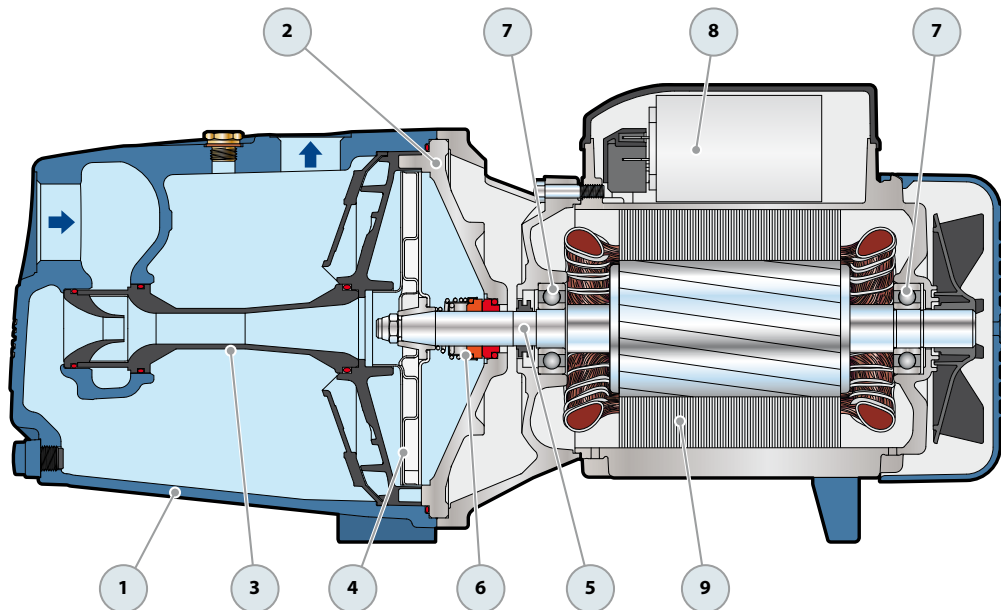

DIMENSIONS AND WEIGHT

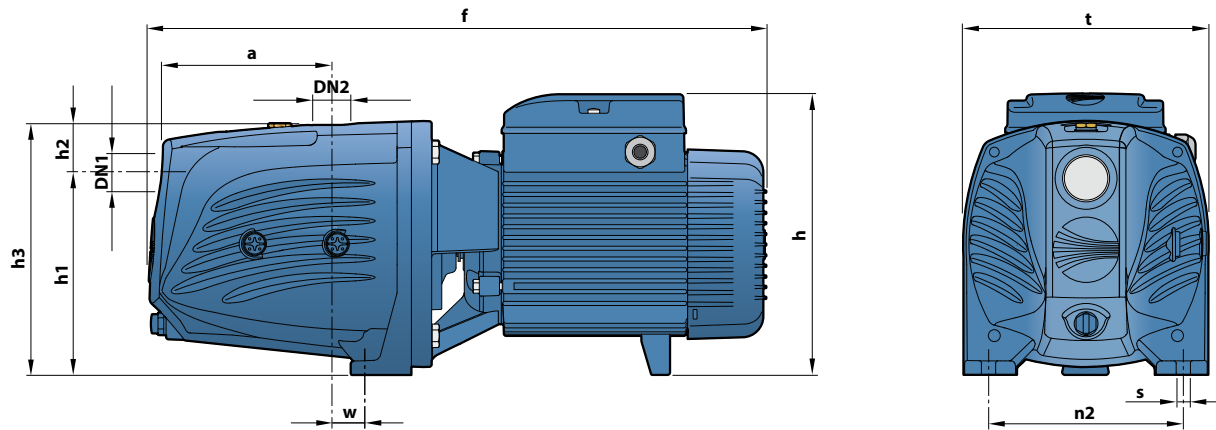

MODEL		PORTS		DIMENSIONS mm										kg	
Single-phase	Three-phase	DN1	DN2	a	f	h	h1	h2	h3	t	n2	w	s	1~	3~
JSWm 3CH	JSW 3CH	1¼"	1"	143	522	240	165	39	204	206	164	30	11	24.2	28.2
JSWm 3BH	JSW 3BH				25.5									25.4	
JSWm 3AH	JSW 3AH				28.2									28.0	
JSWm 3CM	JSW 3CM				24.4									24.4	
JSWm 3BM	JSW 3BM				25.6									25.5	
JSWm 3AM	JSW 3AM				28.0									28.2	
JSWm 3CL	JSW 3CL				24.4									24.3	
JSWm 3BL	JSW 3BL				25.6									25.5	
JSWm 3AL	JSW 3AL				28.2									28.2	

ABSORPTION

MODEL	VOLTAGE		
Single-phase	230 V	240 V	110 V
JSWm 3CH	8.1 A	7.8 A	16.2 A
JSWm 3BH	9.5 A	9.2 A	19.0 A
JSWm 3AH	12.7 A	12.4 A	-
JSWm 3CM	8.1 A	7.8 A	16.2 A
JSWm 3BM	9.7 A	9.4 A	19.4 A
JSWm 3AM	13.0 A	12.5 A	-
JSWm 3CL	8.1 A	7.8 A	16.2 A
JSWm 3BL	10.1 A	9.8 A	20.2 A
JSWm 3AL	13.6 A	13.1 A	-

MODEL	VOLTAGE					
Three-phase	230 V	400 V	690 V	240 V	415 V	720 V
JSW 3CH	5.2 A	3.0 A	1.7 A	5.0 A	2.9 A	1.7 A
JSW 3BH	6.0 A	3.5 A	2.0 A	5.8 A	3.4 A	1.9 A
JSW 3AH	8.8 A	5.1 A	2.9 A	8.5 A	4.9 A	2.8 A
JSW 3CM	5.2 A	3.0 A	1.7 A	5.0 A	2.9 A	1.7 A
JSW 3BM	6.0 A	3.5 A	2.0 A	5.8 A	3.4 A	1.9 A
JSW 3AM	9.0 A	5.2 A	3.0 A	8.6 A	5.0 A	2.9 A
JSW 3CL	5.2 A	3.0 A	1.7 A	5.0 A	2.9 A	1.7 A
JSW 3BL	6.4 A	3.7 A	2.1 A	6.1 A	3.6 A	2.0 A
JSW 3AL	9.3 A	5.4 A	3.1 A	9.0 A	5.2 A	3.0 A

PALLETIZATION

MODEL		GROUPAGE	CONTAINER
Single-phase	Three-phase	n. pumps	n. pumps
JSWm 3CH	JSW 3CH	35	49
JSWm 3BH	JSW 3BH	35	49
JSWm 3AH	JSW 3AH	35	49
JSWm 3CM	JSW 3CM	35	49
JSWm 3BM	JSW 3BM	35	49
JSWm 3AM	JSW 3AM	35	49
JSWm 3CL	JSW 3CL	35	49
JSWm 3BL	JSW 3BL	35	49
JSWm 3AL	JSW 3AL	35	49